

DMC4 4E

SPECIAL SERIES



FAP9 (A) 3/8"	FAP13 (B) 1/2"	FAP15 (C) 5/8"	FAP17 (D) 3/4"	FAP21 (E) 1"	FAP30 (G) 1-1/2"	EC instead of DN9 or DN13
				4 - special FAP21DM		

Technical specifications and options

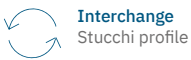

Interchange
Stucchi profile



Sealing
Nitrile NBR



Available sizes
1"



Material
Aluminium, Carbon steel



Valving style
Flat face



Connection Under Pressure
Allowed with Easy CUP



Operating pressure
420 bar (max in 2 lines)



Locking mechanism
Pin, Cam



Temperature
-20°C / +100°C



Connection system
Lever



Available threads
BSP



Flow rate
up to 378 l/min

Benefits

- Specific design for hydraulic lines with 1" (dimension 21): the lever/cam system minimizes the force required to connect the couplings, even with significant pressure trapped in the circuit or under difficult conditions (environment, access, etc.).
- The locking mechanism ensures a full connection and prevents any accidental disconnections.
- Specific indexator avoids misconnection with different mobile plate.
- Special rubber seal prevents dirt inclusion.
- Robust guidance pins guarantee the correct alignment before the connection.
- Parking station and cover plates protect the system from contamination and damage as well as to provide a convenient storage solution.
- The removable lever increases usability reducing the overall dimension.
- Flat face couplings are easy to clean, reducing the inclusion of contamination to the hydraulic circuit.
- Internal valve design creates minimal pressure drop, maintaining circuit efficiency in the system.
- Minimal fluid loss during disconnection, reducing fluid loss to the environment.
- Minimal air inclusion during connection/disconnection.
- High resistance at impulse pressures.
- Safe and simple to use.

Main applications



Features

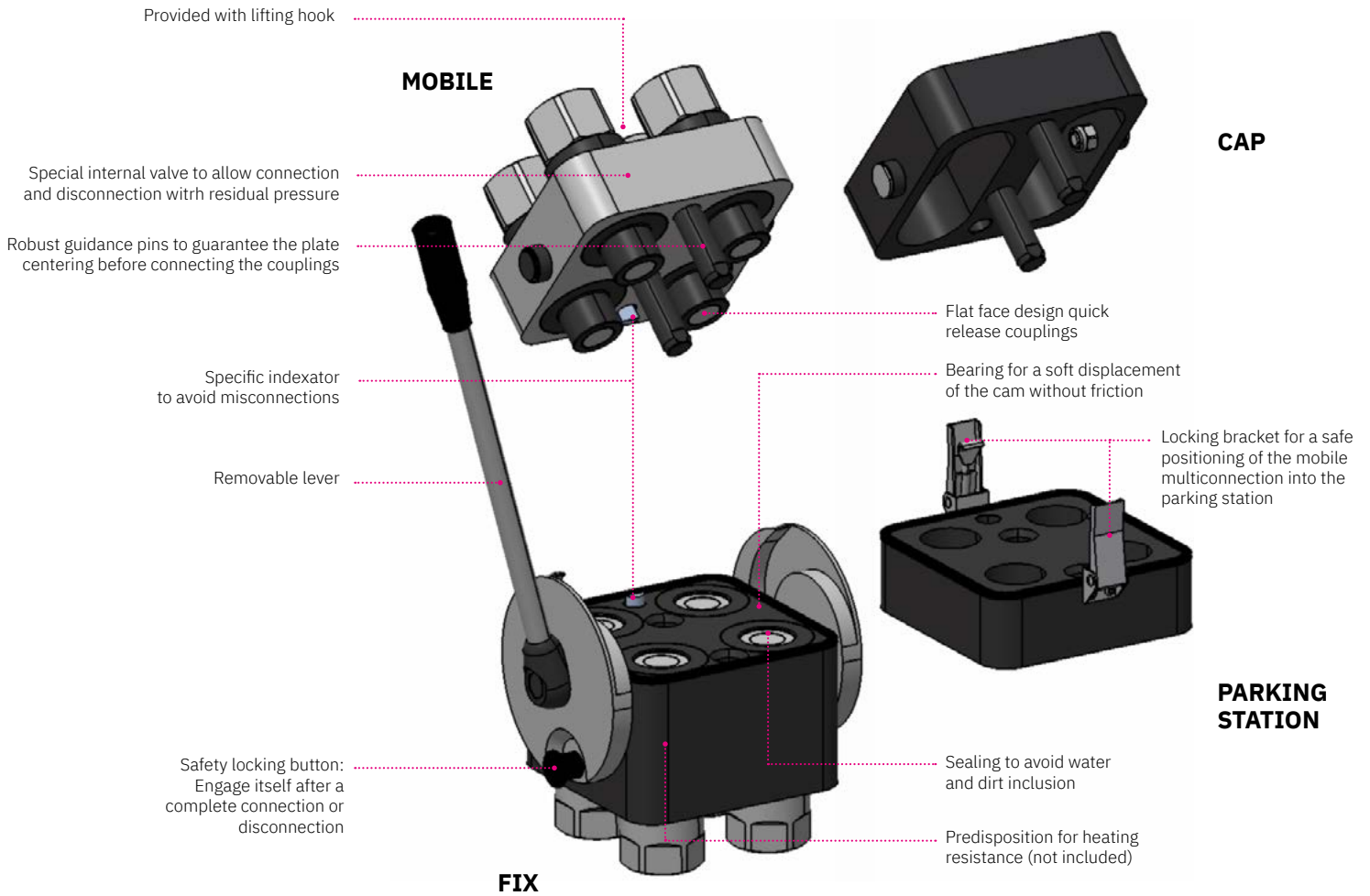

Performances (with FAP21)

Size	Series	Max. flow suggested		Spillage*	Max. operating pressure					
		l/min	GPM		Coupled		Male		Female	
Inch				ml	MPa	psi	MPa	psi	MPa	psi
1	FAP21DM	378	100,17	0,06	42**	-	42	-	30	-

* Spillage is an indicative value of the fluid loss per couple-uncouple cycle.

** Please notice the pressure may only be applied on maximum 2 lines only, the other 2 lines have to be connected to return/drain.

Temperature range: Standard seals NBR, PUR, POM from -20 °C to +100 °C (from -4 °F to +212 °F).

Tests: The couplings have been tested at max. operating pressure for 200.000 impulses in connected position in accordance with ISO norm.

Other threads available upon request.

Installation, use and maintenance

- Install the fixed multiconnection with the proper fixing holes, by referring to the drawing shown in the datasheet.
- Install the flexible hoses on the coupling of the fixed and mobile multiconnection, by screwing them with proper torque.
- Clean the mating surface of the parts prior to connect.
- Insert and lock the removable lever.
- Put the lever of the fixed multiconnection in complete open position, by disengaging the locking button and rotate the lever until the button is again engaged in the open position.
- Connect the mobile multiconnection by engaging the guiding pins into the fixed multiconnection.
- Disengage the locking button then connect the multiconnection by rotating the lever until the stroke is complete and the locking button engaged again in the closed position.
- When the mobile is connected with fixed multiconnection, the cap can be easily parked in the parking station.
- Disconnect the lever from the fixed part in order to avoid injuries from fall or loose it.
- To disconnect the plate, insert the lever and disengage the locking button then rotate by doing vice versa the sequence above described.
- After disconnection, clean the parts and apply the cap on the fixed part then connect the mobile part in the parking station to protect from dust and dirt.
- Disconnect the lever.
- Clean frequently the multiconnection and the components.
- If needed, lubricate the connection and guiding parts.
- Check periodically the multiconnection for leakage, damage or malfunctioning.
- Notice: do not pressurize more than 2 lines together (see “Performances” section).

Configurations

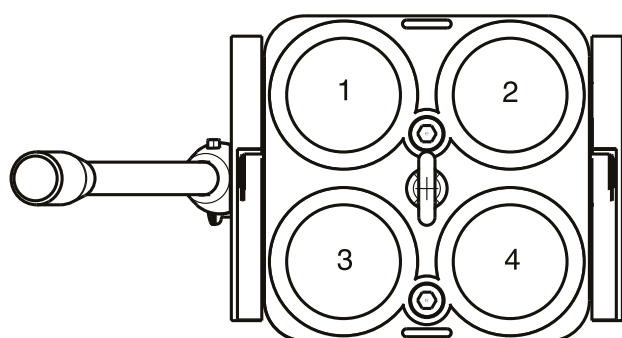

Possible configurations

Position	Coupling Size	Predisposition for electrical connector
1	FAP21 special	-
2	FAP21 special	-
3	FAP21 special	-
4	FAP21 special	-

Plates and spare parts

Multicoupling (couplings included)

Code	Name	Description
870013115	MULTI FIX DMC4 4E Provided with removable lever (included)	4 FAP21DM 1 BSP
870013215	MULTI MOBILE DMC4 4E	4 FAP21DM 1 BSP

Multicoupling spare parts (couplings not included)

Code	Name	Key
806000228	MULTI FIX EMPTY DMC4 4E* Removable lever not included, to be ordered separately	1
806000229	MULTI MOBILE EMPTY DMC4 4E Lifting hook not included, to be ordered separately	2
815701272	SPARE KIT LEVER GROUP DMC L300	3
815606228	CAP FIX MULTICOUPLING DMC 184X160	4
815606229	PARKING STATION MULTICOUPLING MOBILE DMC 160x160	5
815701285	SPARE KIT SEAL MULTICOUPLING FIX DMC4	6

Couplings spare parts

Code	Name	Key
815701287	SPARE KIT SEEGER+M FAP21DM 1 BSP	7
815701288	SPARE KIT SEEGER+F FAP21DM 1 BSP	8
815700345	SPARE KIT OR NBR+BK M FF 100	9

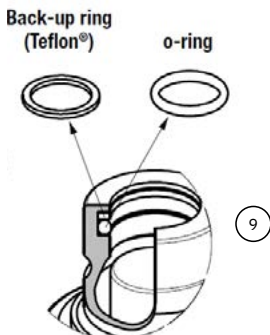
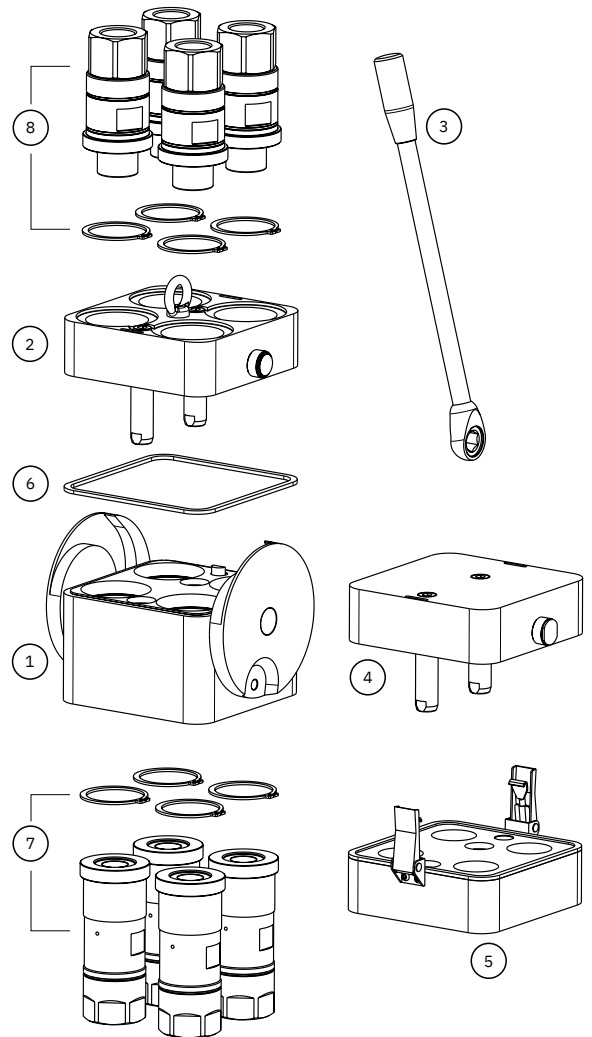

Overall dimensions

Fixed and mobile multicoupling

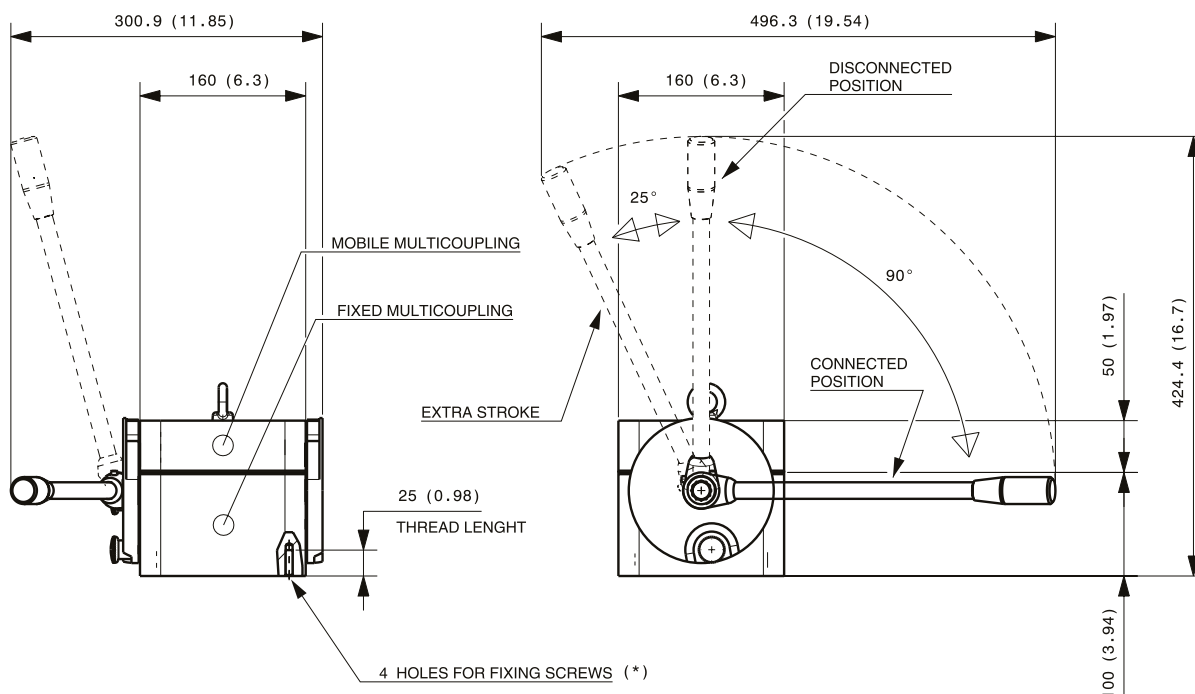

Cap for fix multicoupling

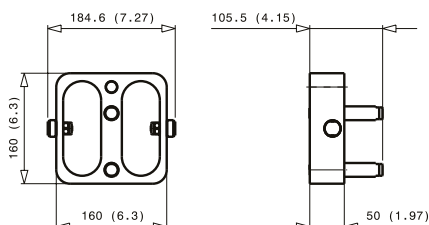

Parking station for mobile multicoupling

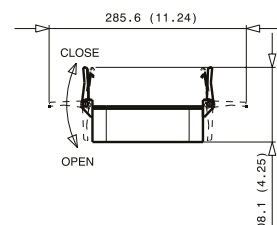
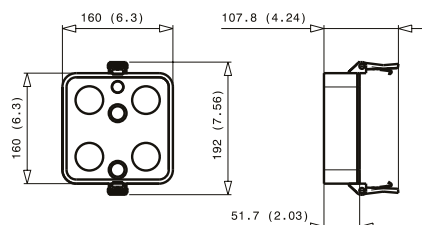

Dimensions in mm (inches)

⚠ WARNINGS

A defect, a wrong choice or an improper use of products, can cause injury to persons, animals and objects.

Connect under pressure products are suitable to be connected under residual (static) pressure.

Never connect or disconnect with dynamic pressure (e.g. pump on).

Do not use the female coupling disconnected with high impulse pressure.

Do not couple-uncouple with flow in the circuit.

Do not couple-uncouple when the temperature inside of the circuit is higher than 80 °C (176 °F).

Check the maximum allowable working pressure of the port in use.

It is important to limit contamination in the circuit to avoid compromising the function of the internal valves.

Make sure that the medium used is compatible with seal and material as indicated for each series.

Do not force the lever without pushing the red safety button.

Do not use extensions or other tools to ease the rotating of the lever.

Do not connect the fixed half with the mobile half if dirt or tools are between them.

Pay attention during the connection not to put finger between the plates.

Do not exceed single coupling performance and total multiconnection resistance of the multiconnection (please refer to dedicated datasheet).

When the multicoupling is disconnected, it is suggested to use the protection cover for the fixed half and the parking station for the mobile half.

Do not to modify, disassemble or damage the multiconnection, part of it or coupling/electrical connector, the lever or safety lock system.

Stucchi Multiconnection DMC. are intended to be used for hydraulic fluid power application: do not use the products for dangerous, inflammable or explosive fluids

The quick coupling FAP-DM series is intended to be used only on Stucchi Multiconnections DMC. Do not use the FAP-DM coupling on a Custom-made multiconnection or other device different than a Stucchi Multiconnection.

In case of doubt please contact Stucchi Technical Support.

It is **MANDATORY** to read and closely follow the instructions. Last updated version always applies at time of installation, see latest Instructions and warnings on Stucchi website (English version: www.stucchigroup.com/en) before selecting or using Stucchi products.



FAP9 (A)	FAP13 (B)	FAP15 (C)	FAP17 (D)	FAP21 (E)	FAP30 (G)	EC
3/8"	1/2"	5/8"	3/4"	1"	1-1/2"	instead of DN9 or DN13
				6 - special FAP21DM		

Technical specifications and options



Interchange
Stucchi profile



Sealing
Nitrile NBR



Available sizes
6 x 1" (special FAP21)



Material
Aluminium, Carbon steel



Valving style
Flat face



Connection Under Pressure
Allowed with Easy CUP



Operating pressure
420 bar (max in 3 lines)



Locking mechanism
Pin, Cam



Temperature
-20°C / +100°C



Connection system
Lever



Available threads
BSP



Flow rate
up to 378 l/min

Benefits

- Specific design for hydraulic lines with 1" (dimension 21): the lever/cam system minimizes the force required to connect the couplings, even with significant pressure trapped in the circuit or under difficult conditions (environment, access, etc.)
- The locking mechanism ensures a full connection and prevents any accidental disconnections.
- Special rubber seal prevents dirt inclusion.
- Robust guidance pins guarantee the correct alignment before the connection.
- Parking station and cover plates protects the system from contamination and damage as well as to provide a convenient storage solution.
- The removable lever increases usability reducing the overall dimension.
- Flat face couplings are easy to clean, reducing the inclusion of contamination to the hydraulic circuit.
- Internal valve design creates minimal pressure drop, maintaining circuit efficiency in the system.
- Minimal fluid loss during disconnection, reducing fluid loss to the environment.
- Minimal air inclusion during connection/disconnection.
- High resistance at impulse pressures.
- Safe and simple to use.

Main applications



Features

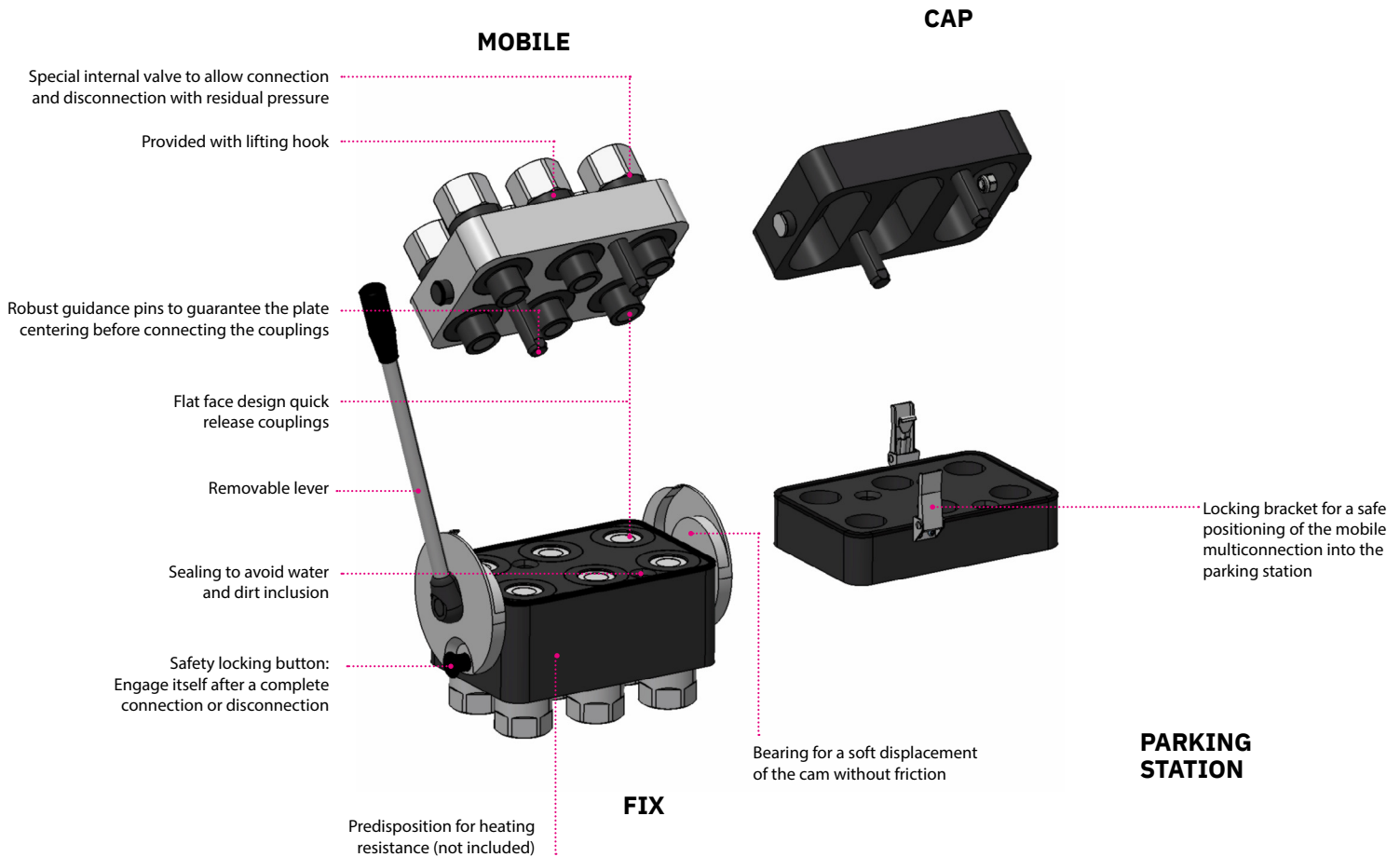

Performances (with FAP21)

Size	Series	Max. flow suggested		Spillage*	Max. operating pressure					
		l/min	GPM		Coupled		Male		Female	
Inch				ml	MPa	psi	MPa	psi	MPa	psi
1	FAP21DM	378	100,17	0,06	42**	-	42	-	30	-

* Spillage is an indicative value of the fluid loss per couple-uncouple cycle.

** Please notice the pressure may be applied on maximum 3 lines, the other 3 lines have to be connected to return/drain.

Temperature range: Standard seals NBR, PUR, POM from -20 °C to +100 °C (from -4 °F to +212 °F).

Tests: The couplings have been tested at max. operating pressure for 200.000 impulses in connected position in accordance with ISO norm.

Other threads available upon request.

Installation, use and maintenance

- Install the fixed multiconnection with the proper fixing holes, by referring to the drawing shown in the datasheet
- Install the flexible hoses on the coupling of the fixed and mobile multiconnection, by screwing them with proper torque
- Clean the mating surface of the parts prior to connect
- Insert and lock the removable lever
- Put the lever of the fixed multiconnection in complete open position, by disengaging the locking button and rotate the lever until the button is again engaged in the open position
- Connect the mobile multiconnection by engaging the guiding pins into the fixed multiconnection
- Disengage the locking button then connect the multiconnection by rotating the lever until the stroke is complete and the locking button engaged again in the closed position
- When the mobile is connected with fixed multiconnection, the cap can be easily parked in the parking station
- Disconnect the lever from the fixed part in order to avoid injuries from fall or loose it
- To disconnect the plate, insert the lever and disengage the locking button then rotate by doing vice versa the sequence above described
- After disconnection, clean the parts and apply the cap on the fixed part, then connect the mobile part in the parking station to protect from dust and dirt
- Disconnect the lever
- Clean frequently the multiconnection and the components
- If needed, lubricate the connection and guiding parts
- Check periodically the multiconnection by looking for leakage, damage or malfunctioning
- Notice: do not pressurize more than 3 lines together (see “Performances” section)

Configurations

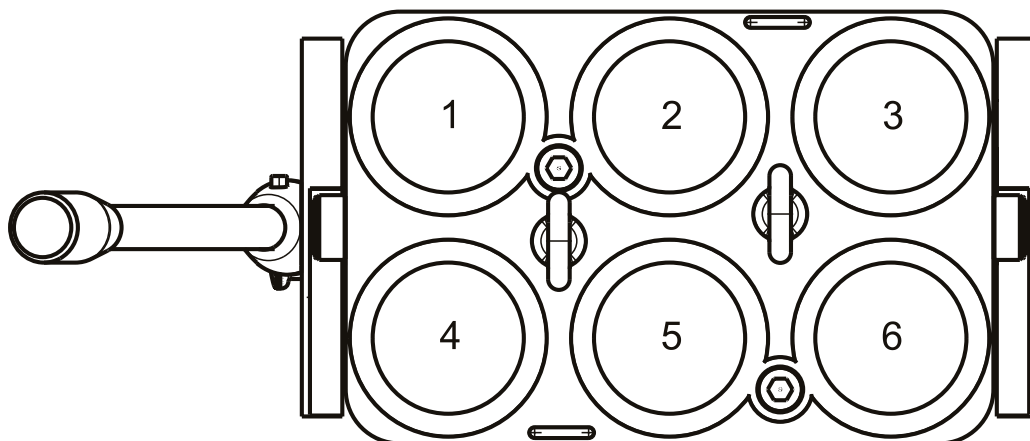

Possible configurations

Position	Coupling Size	Predisposition for electrical connector
1	FAP21 special	-
2	FAP21 special	-
3	FAP21 special	-
4	FAP21 special	-
5	FAP21 special	-
6	FAP21 special	-

Plates and spare parts

Multicoupling (couplings included)

Code	Name	Description
870013114	MULTI FIX DMC6 6E V01 Provided with removable lever (included) Lever on the right	6 FAP21DM 1 BSP
870013116	MULTI FIX DMC6 6E Provided with removable lever (included) Lever on the left	6 FAP21DM 1 BSP
870013214	MULTI MOBILE DMC6 6E	6 FAP21DM 1 BSP

Multicoupling spare parts (couplings not included)

Code	Name	Key
806000234	MULTI FIX EMPTY DMC6 6E V01 Removable lever not included, to be ordered separately Lever on the right Fixed part to be used in code 870013114	1
806000232	MULTI FIX EMPTY DMC6 6E Removable lever not included, to be ordered separately Lever on the left Fixed part to be used in code 870013116	1
806000235	MULTI MOBILE EMPTY DMC6 6E lifting hook not included	2
815701272	KIT COMPLETE LEVER GROUP DMC	3
815606234	CAP FIX MULTICOUPLING DMC6-21	4
815606235	PARKING STATION MULTICOUPLING MOBILE DMC 160x240	5
815701286	KIT SEAL MULTICOUPLING FIX DMC6	6

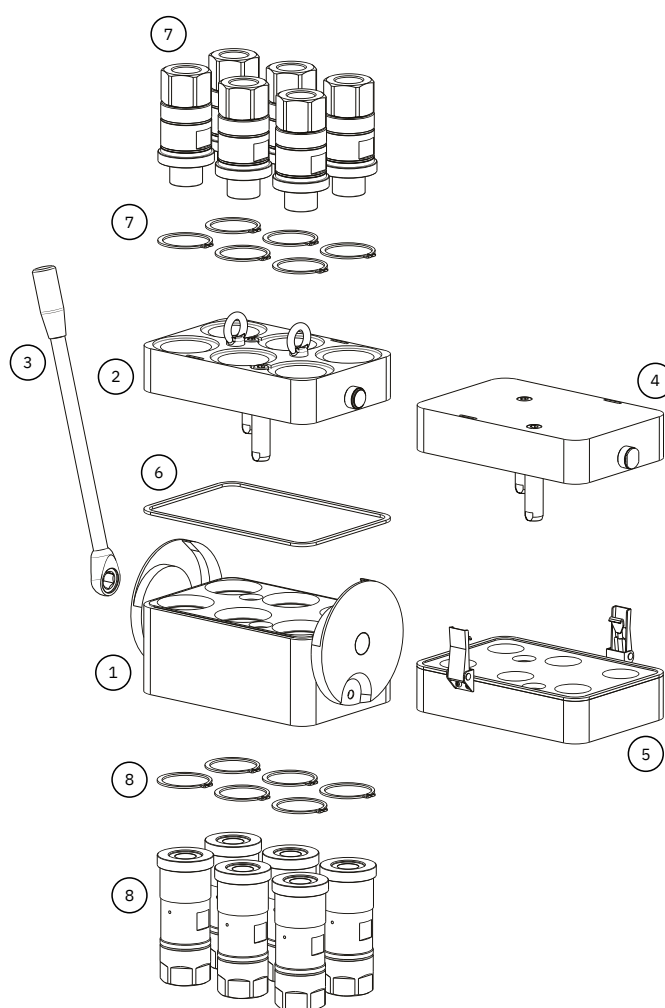

Couplings spare parts

Code	Name	Key
815701287	SPARE KIT SEEGER+M FAP21DM 1 BSP	7
815701288	SPARE KIT SEEGER+F FAP21DM 1 BSP	8
815700345	SPARE KIT OR NBR+BK M FF 100	9

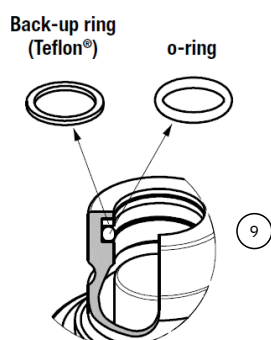

Overall dimensions

Fixed and mobile multicoupling

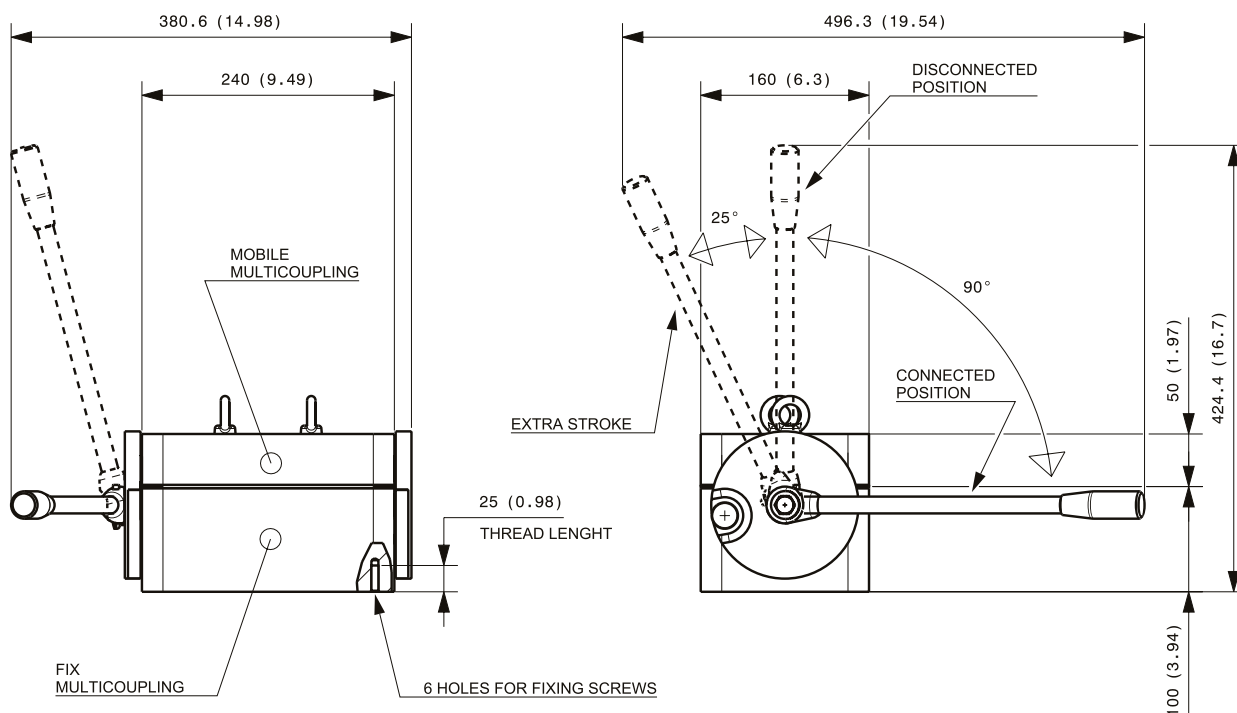

Cap for fix multicoupling

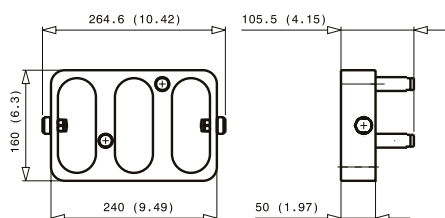

Parking station for mobile multicoupling

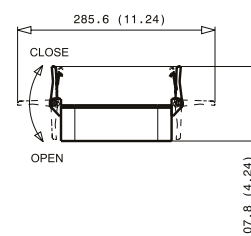
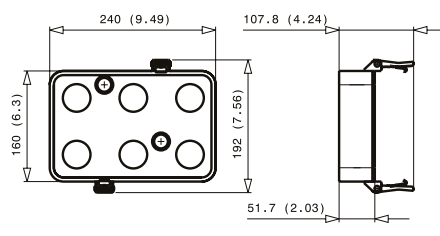

Dimensions in mm (inches)

⚠ WARNINGS

A defect, a wrong choice or an improper use of products, can cause injury to persons, animals and objects. Connect under pressure products are suitable to be connected under residual (static) pressure. Never connect or disconnect with dynamic pressure (e.g. pump on). Do not use the female coupling disconnected with high impulse pressure. Do not couple-uncouple with flow in the circuit. Do not couple-uncouple when the temperature inside of the circuit is higher than 80 °C (176 °F). Check the maximum allowable working pressure of the port in use. It is important to limit contamination in the circuit to avoid compromising the function of the internal valves. Make sure that the medium used is compatible with seal and material as indicated for each series. Do not force the lever without pushing the red safety button. Do not use extensions or other tools to ease the rotating of the lever. Do not connect the fixed half with the mobile half if dirt or tools are between them. Pay attention during the connection not to put finger between the plates. Do not exceed single coupling performance and total multiconnection resistance of the multiconnection (please refer to dedicated datasheet). When the multicoupling is disconnected, it is suggested to use the protection cover for the fixed half and the parking station for the mobile half. Do not to modify, disassemble or damage the multiconnection, part of it or coupling/electrical connector, the lever or safety lock system. Stucchi Multiconnection DMC. are intended to be used for hydraulic fluid power application: do not use the products for dangerous, inflammable or explosive fluids. The quick coupling FAP-DM series is intended to be used only on Stucchi Multiconnections DMC. Do not use the FAP-DM coupling on a Custom-made multiconnection or other device different than a Stucchi Multiconnection. In case of doubt please contact Stucchi Technical Support. It is **MANDATORY** to read and closely follow the instructions. Last updated version always applies at time of installation, see latest Instructions and warnings on Stucchi website (English version: www.stucchigroup.com/en) before selecting or using Stucchi products.